



**Sullivan**  
**Palatek**

# DC210PHJD-260PJD

EXPORT \ TIER 4 INTERIM \ JOHN DEERE ENGINE \ PORTABLE COMPRESSOR



210CFM/150PSI 260CFM/100PSI

# SPECIFICATIONS

## Compressor

Model	DC210PHJD	DC260PJD
Rated Delivery	210 CFM (5.9 m <sup>3</sup> /min)	260 CFM (7.4 m <sup>3</sup> /min)
Rated Operating Pressure	150 psig (10.4 Bar)	100 psig (6.9 Bar)
Operating Pressure Range	70-165 psig (4.8 - 11.3 Bar)	70-125 psig (4.8 - 8.6 Bar)
Estimated Weight, Serviced	2,385 lbs	2,507 lbs
Dimensions L x W x H (in")	134" x 55" x 70"	134" x 55" x 70"

## Engine

Type	Diesel
Make & Model	John Deere 4045 TF290 Tier 4 Interim
Idle Speed	1650 RPM
Fuel Tank Capacity	30 gal (113.6 L)
Horsepower @ rated RPM	74 hp
Full Load Speed	2500 RPM

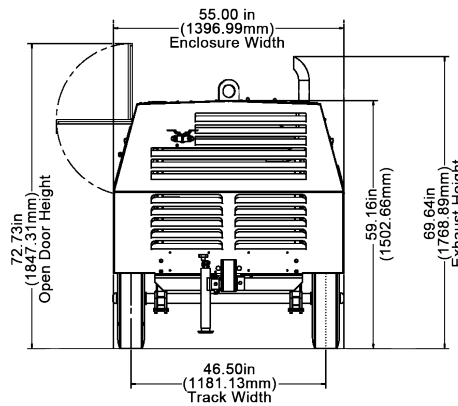
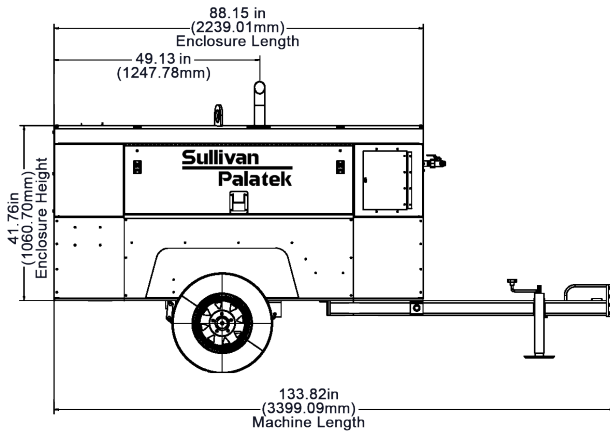

## FEATURES

- » 108mm - 127mm Diameter Twin Screw Air End
- » Exclusive Three Year Warranty On Air End
- » Automatic 0 to 100% Capacity Control
- » Two Stage Dry Type Air Filter - External Access
- » Multiple Service Connections
- » Oil Level Sight Gauge
- » Side by Side Coolers for Compressor and Engine
- » John Deere Engine
- » Steel Fuel Tank
- » Cooler Access Panel for Cleaning
- » Safety Chains
- » 15" Wheels & Tires
- » Choice of Lunnette Eye or Ball Hitch on Height Adjustable Drawbar
- » Large Full Length Tool Boxes in Each Side with Lockable Handles
- » Galvaneal Enclosure
- » Galvanized Wheel Wells and Internal Panels
- » Noise Level Limited to Maximum of 76 dBA at 7 Meters
- » Easily Removable Upper Enclosure
- » Automatic Shutdown and Protection System
- » Automatic Blowdown Valve
- » Stop, Turn, Tail Lights
- » Unloaded Starting

## INSTRUMENTATION

- » Alternator Light
- » Fuel Level Gauge
- » Discharge Pressure Gauge
- » Hourmeter
- » Engine Oil Pressure Gauge
- » Engine Water Temperature Gauge

**Sullivan-Palatek, Inc.**

1201 West US Highway 20  
Michigan City, IN 46360

219.874.2497    [sullivan-palatek.com](http://sullivan-palatek.com)    [info@palatek.com](mailto:info@palatek.com)